

.....

Operating Instructions for the IL-885 In Line Conveyor System



2101 West Cabot Boulevard
Langhorne, PA 19047-1893
www.empire-airblast.com

.....

Model Number: _____ **Serial Number:** _____

Date of Purchase: _____ **Date of Installation:** _____

Distributor Purchased From:

Name: _____

Address: _____

Phone: _____

* * * * *

Manufactured by: EMPIRE ABRASIVE EQUIPMENT COMPANY
2101 West Cabot Boulevard
Langhorne, PA 19047-1893
Phone: 215-752-8800, Fax: 215-752-9373

Empire equipment should be properly maintained per the operating instructions. For peak performance of your equipment, use only genuine Empire replacement parts; accept no substitutes! **The use of non-Empire parts will void the warranty.**

PARTS AND SERVICE
1-800-497-4543

To order Empire replacement parts, contact your local authorized Empire distributor. For the name of your local distributor, call Empire Customer Service, 1-800-497-4543, or fax us at 215-752-9373, or e-mail us on our website www.empire-airblast.com and we will call you back.

CAUTION
*NEVER USE SILICA BASED
ABRASIVES IN EMPIRE BLAST
SYSTEMS*

*Operating Instructions
for the
IL-885 In Line Conveyor System
Empire Abrasive Equipment Company*

03/09/04

Table of Contents

Introduction	5
1.0 Installation	6
1.1 Electrical Connections	6
1.2 Instructions for Making the Electrical Connections	7
2.0 Operation	7
3.0 Daily Maintenance	7
4.0 Weekly Maintenance	7
5.0 Storage or Temporary Non-Use	7
6.0 Troubleshooting	7
7.0 Pneumatic Control Circuit	8
7.1 Principles of Operation	8
7.2 Troubleshooting	9
8.0 Parts Lists	10
8.1 Basic Cabinet Assembly.....	10
8.2 Conveyor Assembly	11
8.3 Electrical Assembly	12
8.4 Pipe String Assembly	13
9.0 Suggested Spare Parts List for 1500 Blasting Hours	14
10.0 Helpful Hints for More Cost-Efficient Blasting	15
10.1 Suggestions for Increasing Blasting Efficiency.....	15
10.2 Suggestions for Enhancing Belt and Conveyor Life.....	15
11.0 Belt Removal and Conveyor Maintenance	16
12.0 Warranty	18

Introduction

Congratulations on your selection of the IL-885 In Line Conveyor System from Empire Abrasive Equipment Company. This manual is provided to help with the unpacking, assembly, use, and maintenance of your IL-885 In Line Conveyor System. *These instructions are for the Cabinet Assembly, Electrical Assembly, Pipe String, and Conveyor Assembly only. Please reference the Operating Instructions for the Pro-Finish Cabinet Systems for instructions pertaining to standard components such as the Reclaimer, Storage Hopper, Blast Guns, and Dust Collector.*

Please read this manual carefully and keep it in the handy plastic pouch attached to your system for future reference. If you have any questions about the operation or maintenance of your equipment, contact your Empire distributor.

Empire: The leader in air-blast technology.

Empire specializes in the design and manufacture of air-blast equipment, and has continued as an industry leader of more than 50 years. Today, Empire produces the most extensive line of air-blast products in the world. In addition to IL-885 In Line Conveyor System, our product line includes PRO-FINISH™ Systems, ProFormer Cabinets, ECON-O-FINISH™ Cabinets, Modified Systems, Automated Blast Systems, Blast Rooms, and SuperBlast™ Portable Blasters.

Empire Abrasive Equipment Company's reputation as a leader in air-blast technology is the result of meeting our customer's demand for quality equipment and systems that deliver increased productivity. We support our equipment with training, service, and testing programs. When you need advice, assistance, or equipment on short notice, our national network of distributors assures that help is nearby.



Figure 1 – IL-885 In Line Conveyor System

1.0 Installation

Reference the *Operating Instructions for the Pro-Finish Cabinet Systems* for

instructions pertaining to install of all components except the electricals.

1.1 Electrical Connections

The standard power source required for the IL-885 systems is 240-volts/60 cycle/single-phase. The IL-885 utilizes a 1 1/2 HP Dust Collector. A minimum

of 15-amp service is required. See Figure 2 below.

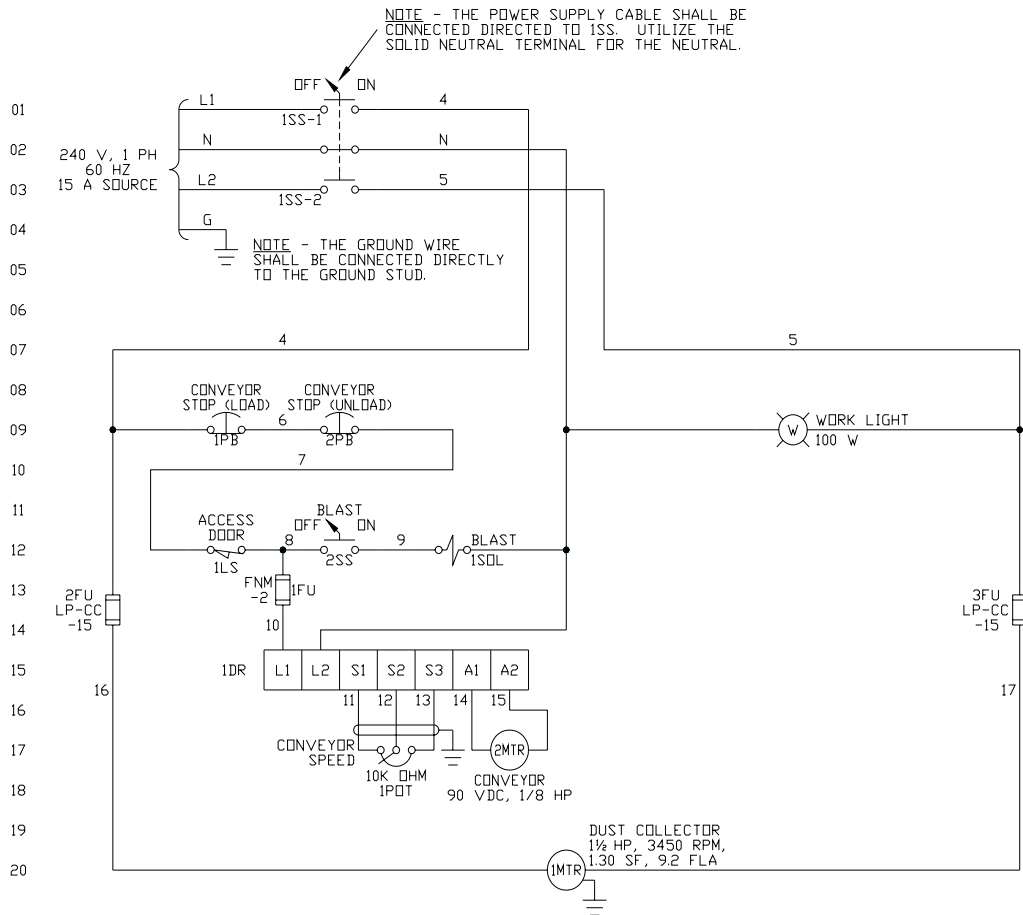

Figure 2 - IL-885 Electrical Diagram

NOTE

All electrical connections to the IL-885 system should be made by a qualified electrician following the adopted codes, standards and procedures specified by the authority having jurisdiction for that location.

1.2 Instructions for Making the Electrical Connections

Step 1: Make the electrical connection between the Fan Motor located on top of the Dust Collector and the Electrical Enclosure located on the Blast Cabinet.

Step 2: Insert the free end of the Fan Motor cord into a suitable customer supplied and installed strain relief in the Electrical Enclosure.

Step 3: Pull approximately 10 inches of cord (all the stripped wire plus 1" of outer insulation) into the Electrical Enclosure. Tighten the strain relief.

Step 4: Connect the numbered wires in the cord to the corresponding numbered left side terminals inside the Electrical Enclosure.

Step 5: Install a suitable customer supplied power cord and second strain relief in the Electrical Enclosure. Connect this cord to the appropriate 1SS connections as shown in Figure 2.

Step 6: Connect the power cord to a 15 amp, 240 volt/60 Hz/1-phase power source.

2.0 Operation

Follow the instructions outlined in the *Operating Instructions for the Pro-Finish Cabinet Systems* for selection of media, media loading, equipment startup, equipment shutdown, and equipment adjustments.

Note that the Conveyor Speed can be adjusted between 1 and 30 feet per minute.

3.0 Daily Maintenance

Follow the instructions outlined in the *Operating Instructions for the Pro-Finish Cabinet Systems*.

4.0 Weekly Maintenance

Follow the instructions outlined in the *Operating Instructions for the Pro-Finish Cabinet Systems*.

5.0 Storage or Temporary Non-Use

Follow the instructions outlined in the *Operating Instructions for the Pro-Finish Cabinet Systems*.

6.0 Troubleshooting

Follow the instructions outlined in the *Operating Instructions for the Pro-Finish Cabinet Systems*.

7.0 Pneumatic Control Circuit

7.1 Principles of Operation

The IL-885 In Line Conveyor System uses an electrical control circuit to activate the Interlock Solenoid Valve. This valve pneumatically opens the Main Air Valve.

When the Power Switch (1SS) is turned to ON, the Access Door is closed, and the two Conveyor Stop Pushbuttons are disengaged, the pneumatic circuit works as follows:

Step 1: When the Blast Selector Switch is turned to ON, the Interlock Valve opens and the control line to the Main Air Valve pressurizes. This action opens the valve and blast starts.

Step 2: When the Blast Selector Switch is turned to OFF, the Interlock Valve

closes and the control line to the Main Air Valve depressurizes. This action closes the Main Air Valve and blast stops.

Step 3: When the Access Door is opened or a Conveyor Stop Pushbutton is engaged, an electrical contact is opened. This prevents the Interlock Valve from pressurizing the Main Air Valve control line and blast cannot occur.

See Figure 3 for an illustration of the pneumatic control circuit in blast and non-blast modes. Note that in this figure pressurized piping is shown darkened.

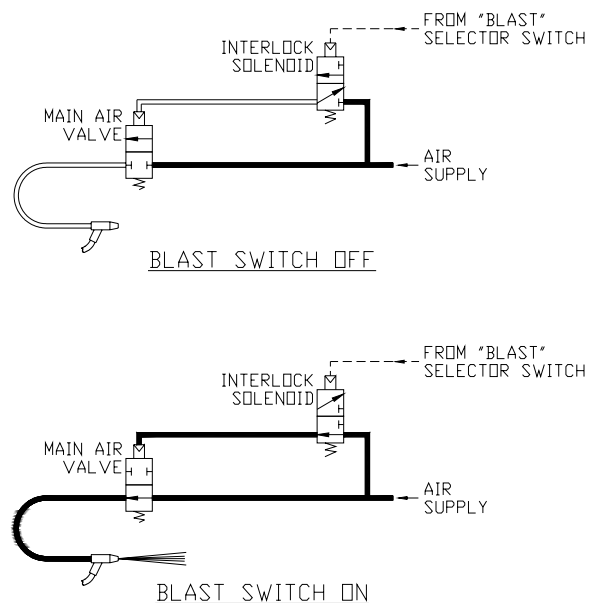

Figure 3 – IL-885 Pneumatic Control Circuit

7.2 Troubleshooting

Refer to Figure 4. If the Dust Collector Fan Motor is running, the Cabinet light is ON, the Blast Selector Switch is ON, and the Conveyor is running but the system will not blast, perform the following steps:

Step 1: Make sure the plant compressed air supply valve is ON.

Step 2: Make sure the pressure regulator is set above zero.

Step 3: Make sure the individual Blast Gun ball valve is ON.

Step 4: Turn the Blast Selector Switch from ON to OFF. You should hear a slight hiss from the exhaust port of the

Interlock Solenoid. If this sound is heard, skip to Step 6.

Step 5: If no sound is heard, there is an air leak in the control line between the Interlock Solenoid (Point B) and the Main Air Valve (Point C). Disconnect the control air line at Point C. Turn the Blast Selector Switch to ON. Air should blow out of the open hose end. If there is no air, the solenoid valve is not functioning and must be replaced.

Step 6: Turn the Blast Selector Switch to ON. Check the vent on the spring retainer nut of the Main Air Valve (Point C) for leaking air. If air is leaking from the vent, the valve diaphragm is damaged and must be replaced or the valve must be rebuilt.

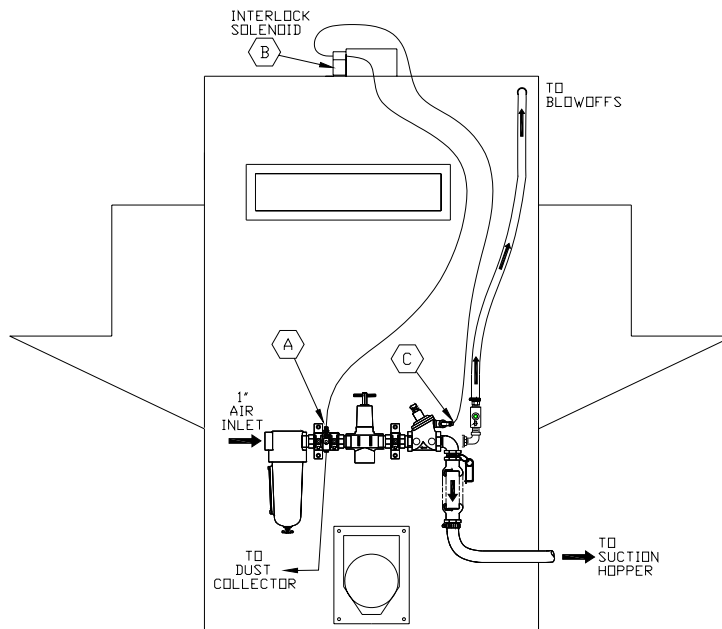

Figure 4 – IL-885 Cabinet Rear View

8.0 Parts Lists

IMPORTANT

These parts lists specify only the parts which are specific to the IL-885. For parts that are common to both the IL-885 and Pro-Finish cabinets (e.g., windows, gaskets, blast hose, blast nozzles, etc.), see the parts lists in the *Operating Instructions for the Pro-Finish Cabinet Systems*.

8.1 Basic Cabinet Assembly

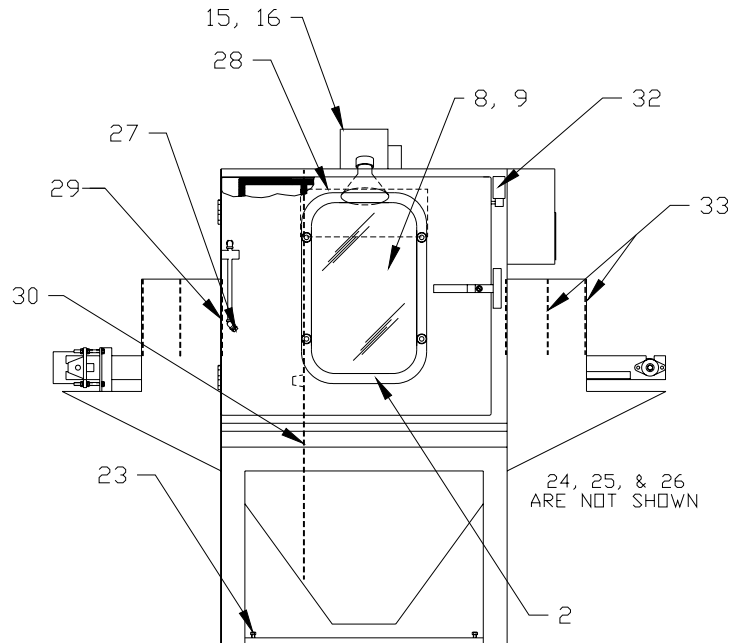

Figure 5 - IL-885 Basic Cabinet Assembly

Item	Part Number	Description	Quantity
2	524853	Window Support Gasket	6"
8	509191	Optional Plastic Window Protector *	1
9	509201	Optional Screen Window Protector	1
15	510495	Kleensweep Inlet Filter *	1
16	510481	Kleensweep Inlet Screen	1
23	553892	3/8" -16 x 2" Leveling Bolt	4
24	567391	Instruction/Warning Label	1
25	564305	Empire Logo	1
26	564301	Label	10'
27	503503	Blowoff Nozzle	2
28	580341	Hose Entry Gasket	1
29	580331	Inner Curtain *	2
30	580311	Rubber Interior Wall *	1
32	534333	Limit Switch	1
33	580321	Outer and Middle Curtain *	4

* Consumable wear item. Recommended to keep in stock.

8.2 Conveyor Assembly

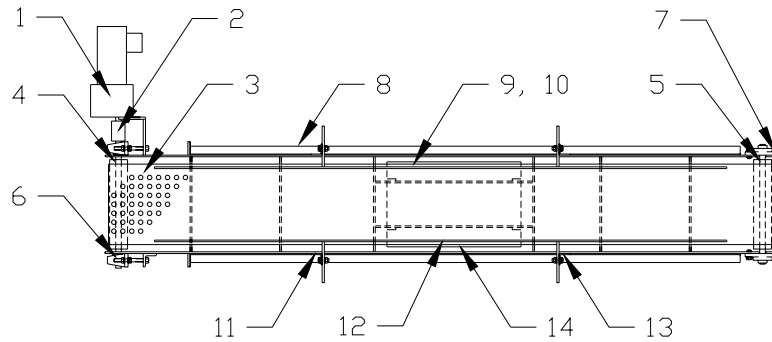

Figure 6 - IL-885 Conveyor Assembly

Item	Part Number	Description	Quantity
1	549491	90 VDC Gearmotor	1
2	570693	2-piece Coupling	1
3	600161	Conveyor Belt, Standard	1
	600160	Conveyor Belt, Optional Heavy Duty	1
4	571561	Exit Pulley, Crowned, Plain	1
5	571551	Entrance Pulley, Crowned, Winged	1
6	571541	Bearing, Pillow Block	2
7	571531	Bearing, Two-bolt Flange	2
8	773231	Frame Weldment	1
9	773241	Blast Plate	1
10	523733	Protective Sheeting, 15" x 9 1/2", bonded to Blast Plate	1
11	773251	Left Rail Support	1
12	773271	Rail Weldment	1
13	773261	Right Rail Support	2
14	770106	Belt Support Bar **	2

** Replacement part only.

8.3 Electrical Assembly

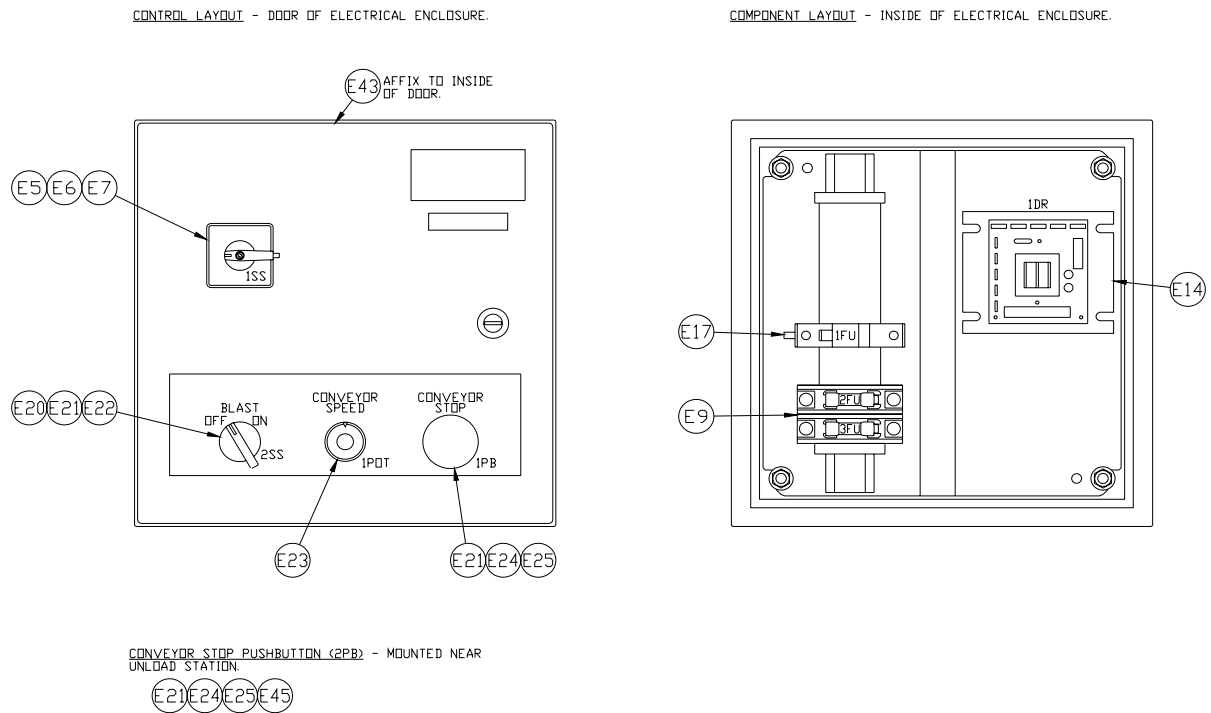

Figure 7 – IL-885 Electrical Assembly

Item	Part Number	Description	Quantity
E5	534921	Switch Body, 40 amp	1
E6	534931	Actuator	1
E7	533551	Neutral Terminal	1
E9	532441	Fuse, 15 amp	2
E14	535003	DC Motor Control	1
E17	531921	Fuse, 2 amp	1
E20	534981	Selector Switch Operator	1
E21	530821	Mounting Latch	3
E22	534971	Normally Open Contact	1
E23	534951	Potentiometer Operator	1
E24	534941	Mushroom Head Pushbutton Operator	2
E25	534961	Normally Closed Contact	2
E43	565351	Electrical Schematic Label	1
E45	535121	Pushbutton Enclosure	1

8.4 Pipe String Assembly

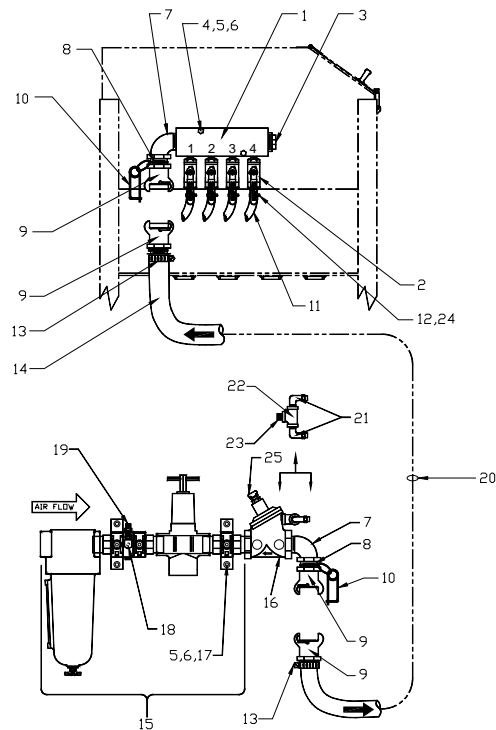

Figure 8 - IL-885 Pipe String Assembly

Item	Part Number	Description	Quantity
1	504025	Air Manifold, 4-Gun, Aluminum	1
2	518472	1/2" Ball Valve	4
3	544122	1" Plug	1
4	551802	1/4" - 20 x 3" Bolt	2
5	552882	1/4" Flat Washer	6
6	552522	1/4" x 20 Nut	6
7	543542	1" Street Elbow	1
8	546202	1" Close Nipple	1
9	505782	1" Tank Coupling	4
10	510511	Safety Pin	2
11	520861	1/2" Air Hose	32 feet total
12	520502	1/2" Hose Clamp	8
13	520581	1" Hose Clamp	2
14	520912	1" Air Hose	12 feet
15	140280	1" Pipe String (see the Pro-Finish operating instructions)	Reference
16	517042	1" Aquamatic Valve	1
17	564121	1/4" - 20 x 3/4" Flat Head Socket Screw	4
18	520242	Brass Elbow, 1/4" MPT x 1/4" Tube	1
19	520222	Brass Connector	1
20	140304	1" Hose Assembly	Reference
21	520432	Brass Elbow, 1/8" MPT x 1/4" Tube	2
22	545572	1/8" Tee, BMI	1
23	545902	1/8" Close Nipple	1
24	546022	1/2" Close Nipple	4
25	523261	Breather Vent, 1/8" NPT	1

9.0 Suggested Spare Parts List for 1500 Blasting Hours

IMPORTANT

This parts list specifies only the parts that are specific to the IL-885. For parts that are common to both the IL-885 and Pro-Finish cabinets (e.g., windows, gaskets, blast hose, blast nozzles, etc.), see the parts lists in the *Operating Instructions for the Pro-Finish Cabinet Systems*.

Item	Part Number	Description	Quantity
1	600161	Conveyor Belt, Standard	1
	600160	Conveyor Belt, Optional Heavy Duty	1
2	571541	Bearing, Pillow Block	2
3	571531	Bearing, Two-bolt Flange	2
4	549491	90 VDC Gearmotor	1
5	773241	Blast Plate	1
6	523733	Protective Sheeting, 15" x 9 ½"	1
7	773271	Rail Weldment	2
8	770106	Belt Support Bar	2

10.0 Helpful Hints for More Cost-Efficient Blasting

10.1 Suggestions for Increasing Blasting Efficiency

1: Adjust the Conveyor speed slow enough so that the Blast Nozzle spray pattern cleans a full path on the part in one pass.

2: If a wide part is being processed, arrange the Blast Nozzles to clean only one half of the part. Rotate the part so that the unprocessed side will be blasted when run through the system a second time.

10.2 Suggestions for Enhancing Belt and Conveyor Life

1: Place the parts to be processed close together on the conveyor to limit overspray onto the belt and conveyor components.

3: If the conveyor or belt is being eroded by direct blast or overspray, reposition the guns to blast in a different direction.

2: Adjust the nozzles so that only the part to be processed is blasted, not the surrounding components. See Figure 9.

4: For harsh media applications, utilize the Optional Heavy Duty Conveyor Belt, part number 600160.



Figure 9 - IL-885 Blast Guns

11.0 Belt Removal and Conveyor Maintenance

Follow this procedure to remove the conveyor belt and to perform maintenance. Refer to Figure 10 and Figure 11.

Step 1: Turn the Electrical Disconnect to OFF and shut off air to the system. Lockout/Tagout these energy sources as required.

Step 2: If guide rails and rail supports are being utilized to process parts, remove the four bolts that secure them.

Step 3: Remove two bolts attaching the Conveyor Frame to the Blast Cabinet.

Step 4: Disconnect the electrical cord connected to the belt drive gearmotor.

Step 5: Slide out the entire conveyor assembly to the left. Place the assembly on a workbench.

CAUTION

It is strongly recommended that two people move the conveyor assembly.

Step 6: Relax the belt tension by loosening the pillow block bearing support nuts on the exit end of the conveyor.

Step 7: Remove the entrance pulley by removing the four bolts holding the two 2-bolt flange bearings in place.

Step 8: Lift the pulley and slide it and the bearings out of the belt.

Step 9: Remove the belt by sliding it sideways off of the frame.

Step 10: Remove and replace parts as required.

Step 11: Reassemble the conveyor assembly by reversing steps 1 through 9.

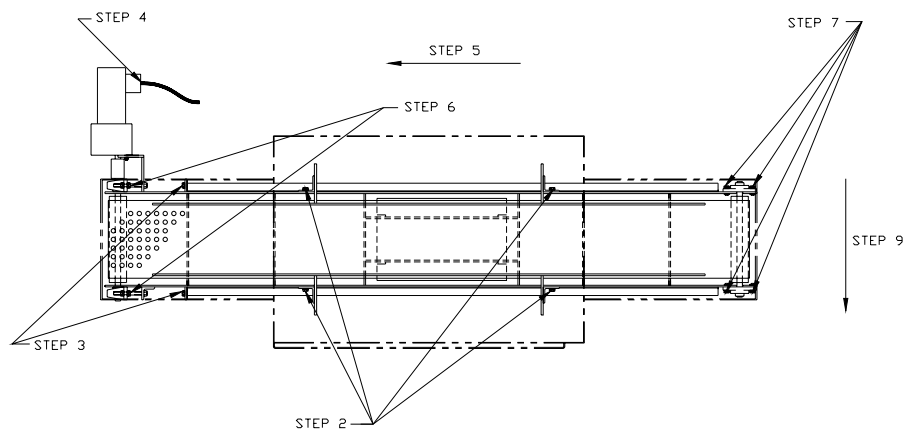

Figure 10 – IL-885 Conveyor/Belt Removal

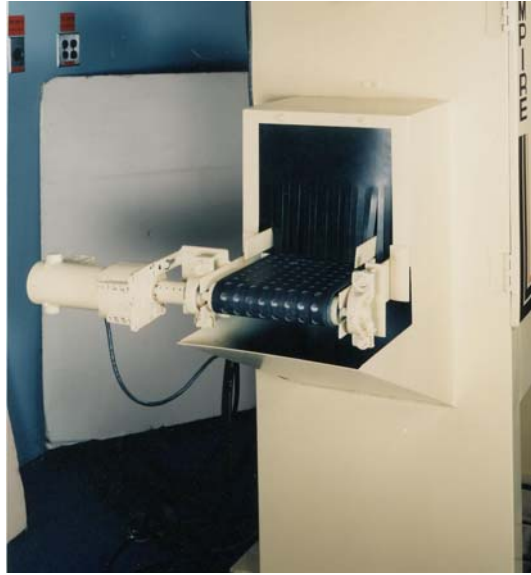

Figure 11 - IL-885 Conveyor Exit

12.0 Warranty

Empire Abrasive Equipment Company (“Empire”) warrants all parts and equipment against defect in material and workmanship to the original purchaser for a period of **three (3) years** after shipment. Upon prompt notification by the buyer, to Empire, components that are determined by Empire to be defective will be repaired or replaced at not additional charge.

LIMITATIONS:

1. This warranty does not apply to normal wear items such as nozzles, blast hose, and reclaimers or to other components that are exposed to direct contact with blast media.
2. The buyer must follow all recommended maintenance schedules; see Operating Instruction on prior pages.
3. Does not apply to misapplication of product.
4. Unauthorized service, repair, improper installation, improper operation, improper maintenance, alternations, misuse, neglect, accident or excessive ambient conditions will void the warranty.
5. **If genuine Empire replacement parts are not used the warranty is void.**
6. Returned Material Authorization (RMA) form must be completed and accompany all returned goods. Returns are not recognized without prior authorization and RMA number.
7. Associated installation costs are excluded.
8. Freight costs for goods returned to Empire are to be assumed by the buyer unless the parts are determined defective by Empire.
9. Parts that are not supplied by Empire are not covered. Commercial components are warranted under term of the original manufacturer.